

THIS DIAGRAM SHOWS NORMAL LAND-LINE CONNECTIONS FROM ONE LAND-LINE AND A BLUETOOTH CONVERTER (BTC) IN STAND-ALONE MODE
NORMAL TELEPHONE 3 TWISTED PAIR CABLE

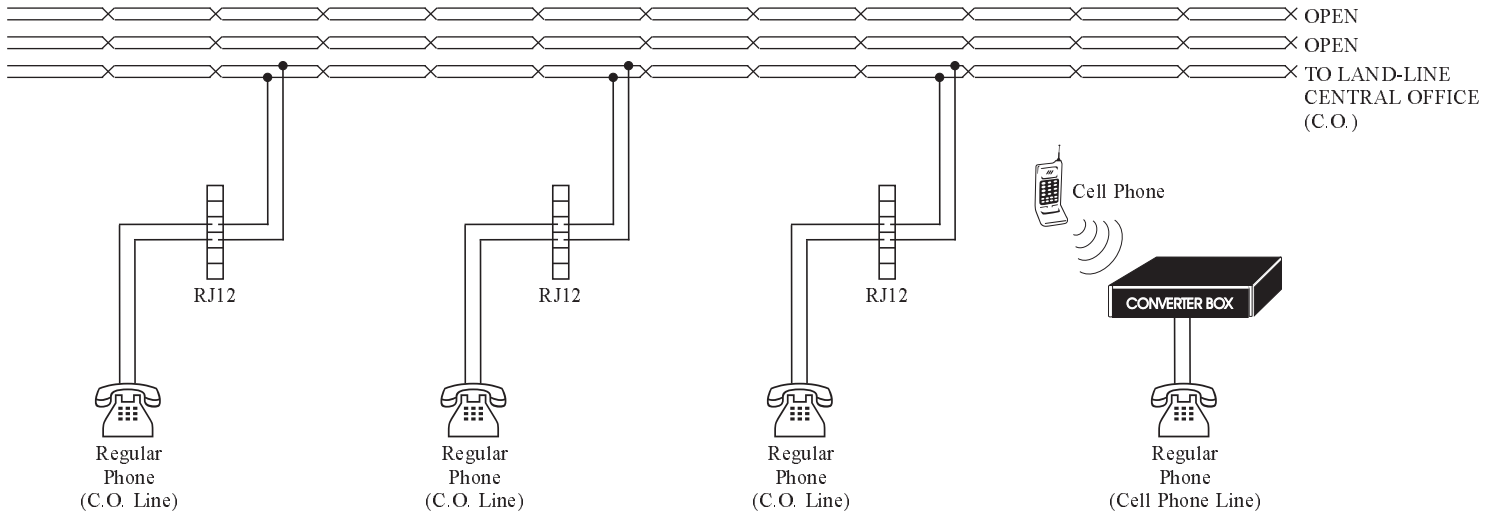

THIS DIAGRAM SHOWS THE CONNECTIONS WHEN THE LAND-LINE IS ELIMINATED AND THE CELL PHONE LINE IS DISTRIBUTED ON THE SAME LINE

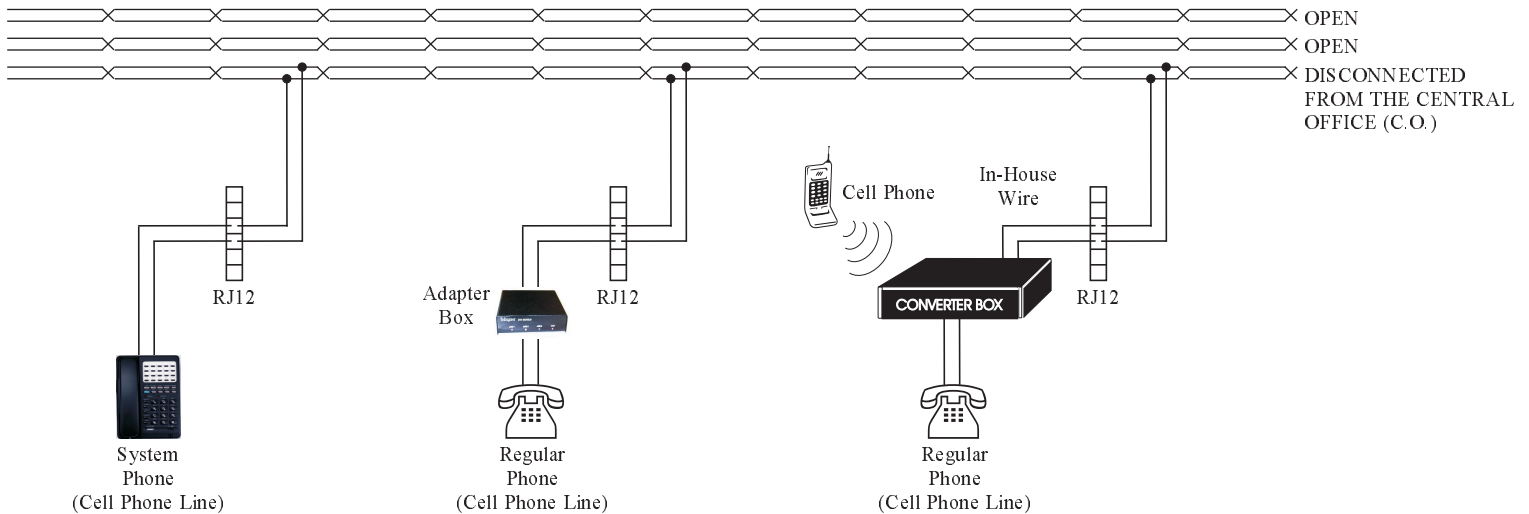

THIS DIAGRAM SHOWS THE CONNECTIONS WHEN THE C.O. LINE IS CONNECTED AND THE BLUETOOTH CONVERTER IN-HOUSE CONNECTOR IS TIED TO ANOTHER PAIR OF WIRES IN THE CABLE

